

SOTTOBASE E BASE ADATTATRICE Skillair®

La base adattatrice consente al sistema FRL SKILLAIR® di adattarsi ai vari montaggi speciali, mantenendo inalterate le caratteristiche di componibilità e manutenzione. L'utilizzo della base adattatrice universale più la piastra intermedia permette inoltre di assemblare più elementi di varie taglie.



DIMENSIONI	100 - 2 POS.	100 - 3 POS	200 - 2 POS	200 - 3 POS	300 - 2 POS	300 - 3 POS
A	50	50	55	55	60	60
B	34	34	44	44	49	49
C	113	165	135	200	155	230
D	52	52	65	65	75	75
E	10	10	8.5	8.5	10.5	10.5
F	G 1/2	G 1/2	G 3/4	G 3/4	G 3/4	G 3/4
G	30	30	40	40	40	40
L	128	180	150	215	170	245

SOTTOBASE A 2 POSIZIONI

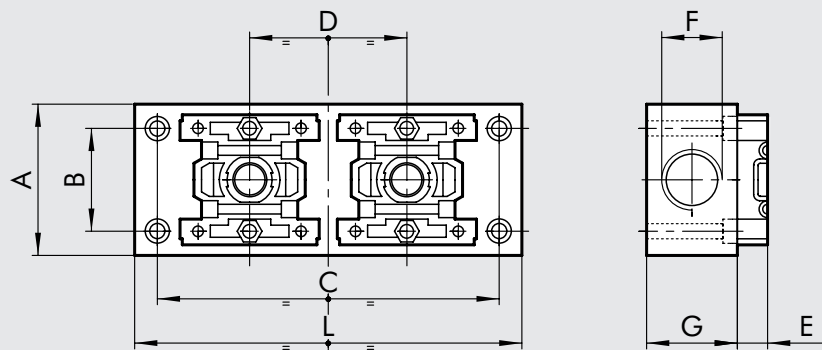

SOTTOBASE A 3 POSIZIONI

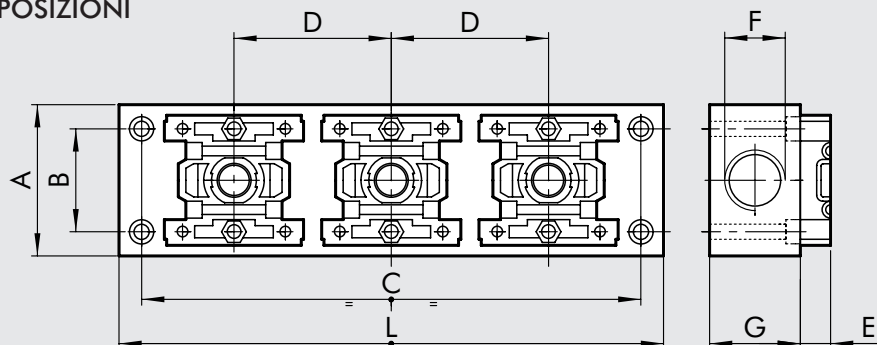

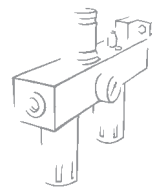

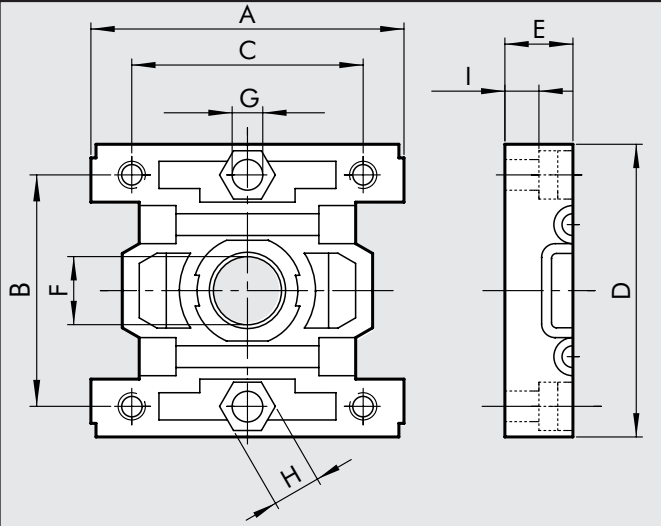
DIMENSIONI BASE ADATTATRICE	BA 100	BA 200	BA 300
	A: 46 B: 34 C: 34 D: 43 E: 10 F: 10 G: Foro X M4 Es. 7 I: 5	A: 59 B: 44 C: 44 D: 55 E: 8.5 F: 15 G: Foro x M4 Es. 7 I: 2	A: 69 B: 49 C: 49 D: 65 E: 10.5 F: 18 G: Foro x M5 Es. 8 I: 5

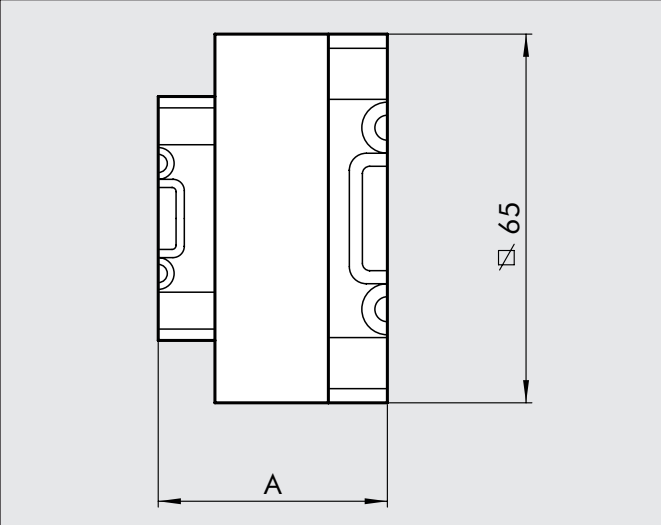
DIMENSIONI ADATTATORI DI TAGLIA	BA 100 - 200	BA 100 - 300	BA 200 - 300
	A: 38.5	A: 40.5	A: 39

CODICI DI ORDINAZIONE	NOTE
Cod. Descrizione	
SOTTOBASI MULTIPLE PER REGOLATORI	
9200202	ACC. SB 2 100
9300202	ACC. SB 2 200
9400202	ACC. SB 2 300
9200302	ACC. SB 3 100
9300302	ACC. SB 3 200
9400302	ACC. SB 3 300
BASE ADATTATRICE	
9201801	BA 100
9321801	BA 200
9401801	BA 300
ADATTATORI DI TAGLIA	
9301801	BA 100 - 200
9301802	BA 100 - 300
9301803	BA 200 - 300